

Sill Deck

Replacement Instructions



8817 West Market Street
Colfax, NC 27235 | 800.334.2006
www.enduraproducts.com

Tools/Materials Required:

- Pencil or Marker
- Measuring Tape
- Cutting Tool
- Construction Adhesive
- Caulk

STEP 1: MEASURE THE EXISTING SILL

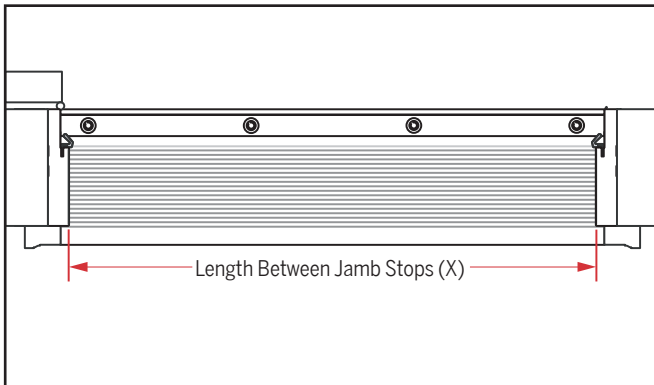

For **7-13/16" wide** sills, measure the length only.

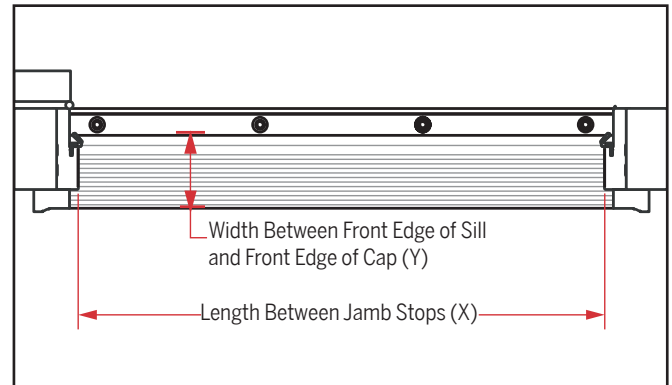

For **all other width** sills, measure the length and the width.

STEP 2: MARK AND CUT THE REPLACEMENT SILL DECK

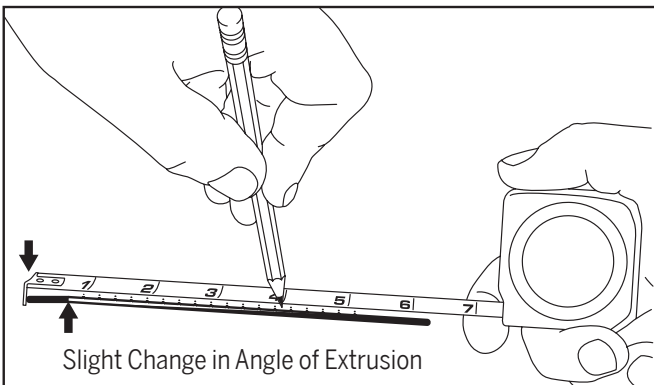

a. Measure and mark sill repair aluminum from the edge the arrows point to.

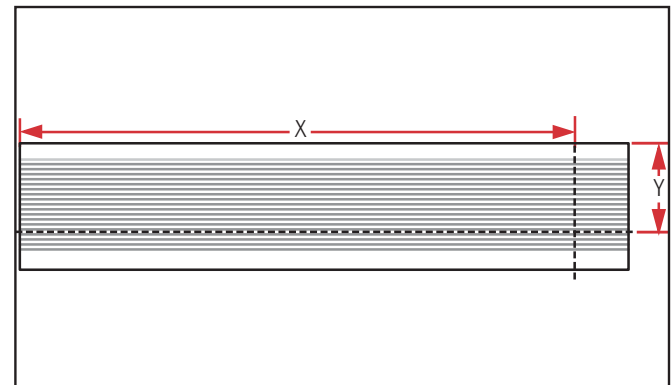

b. Cut the replacement sill deck to the measured width (unless 7-13/16" wide sill). Remove sharp edges from all areas.

SKU: BD-INST-REPDECK

Rev. Date: 08.10.2017

©Endura Products, Inc.

US Patents: 6,789,358; 7,350,336; 5,588,266;

5,611,173; 5,426,894; D354,572

STEP 3: APPLY ADHESIVE TO EXISTING SILL

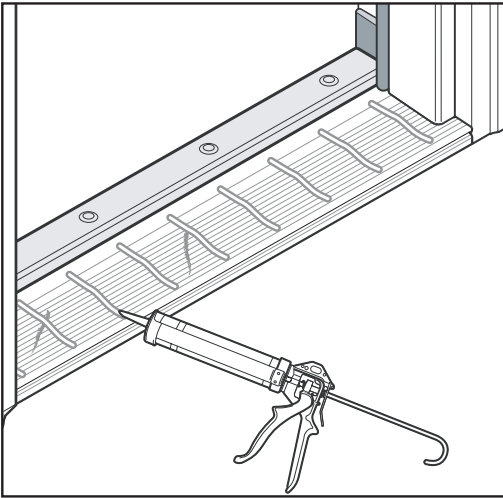

- a. Apply construction adhesive (such as Liquid Nails) as rows along the surface of the existing sill.

STEP 4: APPLY REPLACEMENT SILL DECK TO SILL

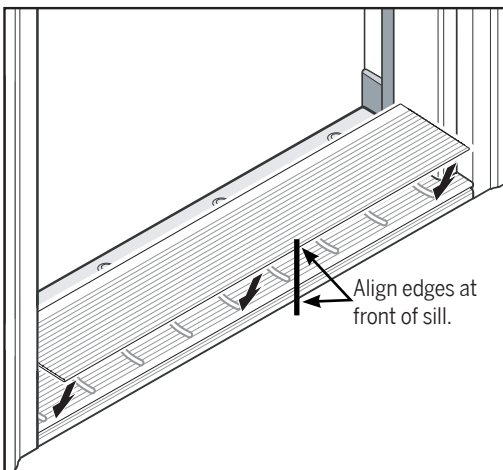

- a. Place sill repair aluminum on top of existing sill, aligning front edge of sill repair aluminum with front edge of existing sill.
- b. Press sill repair aluminum firmly into place. Wipe away any excess adhesive. Check alignment of front edges.

STEP 5: CAULK ENDS OF REPLACEMENT SILL DECK

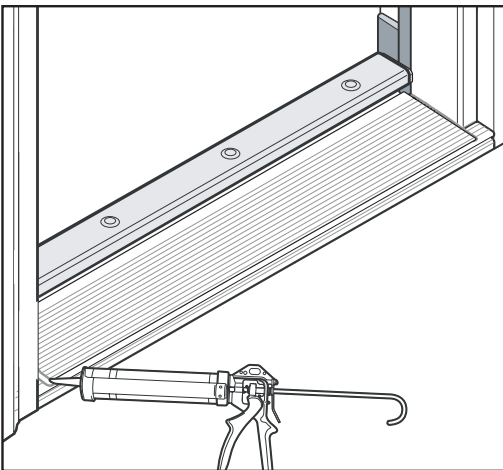

- a. Caulk both ends of the replacement sill deck. Allow all caulk and adhesive to dry before stepping on sill.