

Endura Z-Articulating Cap Sill™ Retrofit Kit for French Doors

Installation Instructions

Before you begin:

- This retrofit kit is designed for the Endura Z-Series sill. Please ensure it is compatible with your current sill before you begin installation.
- When replacing the sill cap for your French Door you will also have to update components around the bottom of your door panel. These steps (Part B) will require you to remove both door panels off the frame. **We recommend you use assistance while doing this.**

TOOLS REQUIRED:

- Flathead screwdriver
- Small wooden block or thin board
- Measuring Tape
- Pen or Pencil
- Cutting Tool: Chop/Miter Saw recommended
- 1/2" crown Staples
- 7/8" Diameter drill bit

If you already have a ZAC 2.0 sill, you will also need:

- Scraping Tool
- Caulk

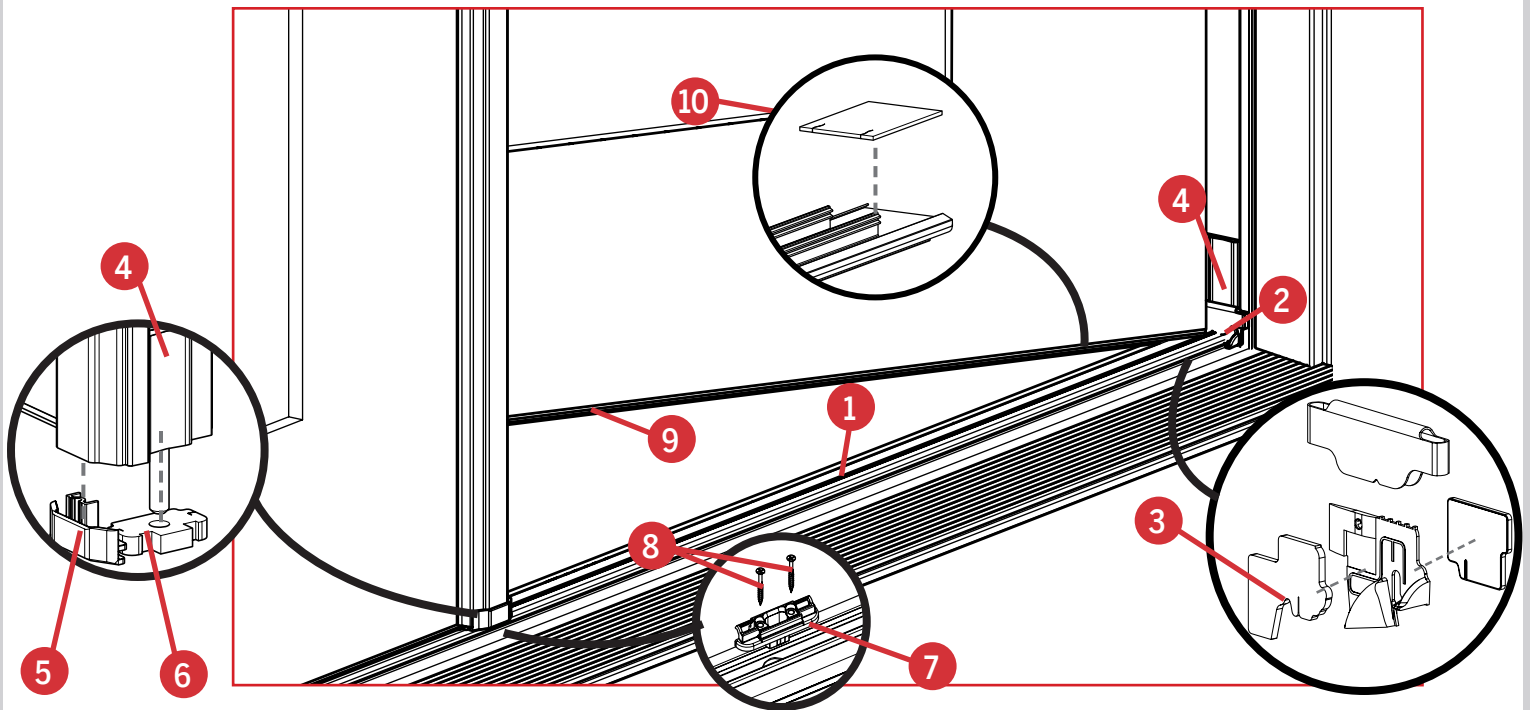

KIT INCLUDES:

1. 6' Z-Articulating Cap (1)
2. Z-End Base™ Mull Stiffeners (2)
3. Active Mull Stiffener Gaskets (Use if you are replacing an existing Z-AC sill) (2)
4. Simple Solution™ Corner Pads (3)
5. Astragal Lower Trim Cap (White and Bronze - you will only use one).
6. Bottom Pad for Astragal Boot (1)
7. Bolt Receiver Pin Capture (1)
8. Pin Capture Mounting Screws (2)
9. Door Bottoms (Kerfed and Staple-On - you will only use one)
10. Door Bottom Gasket for Kerfed Door Bottoms (2)

PART A: PREPARE FOR INSTALL

Step 1: Remove the following door components from around the sill of your door:

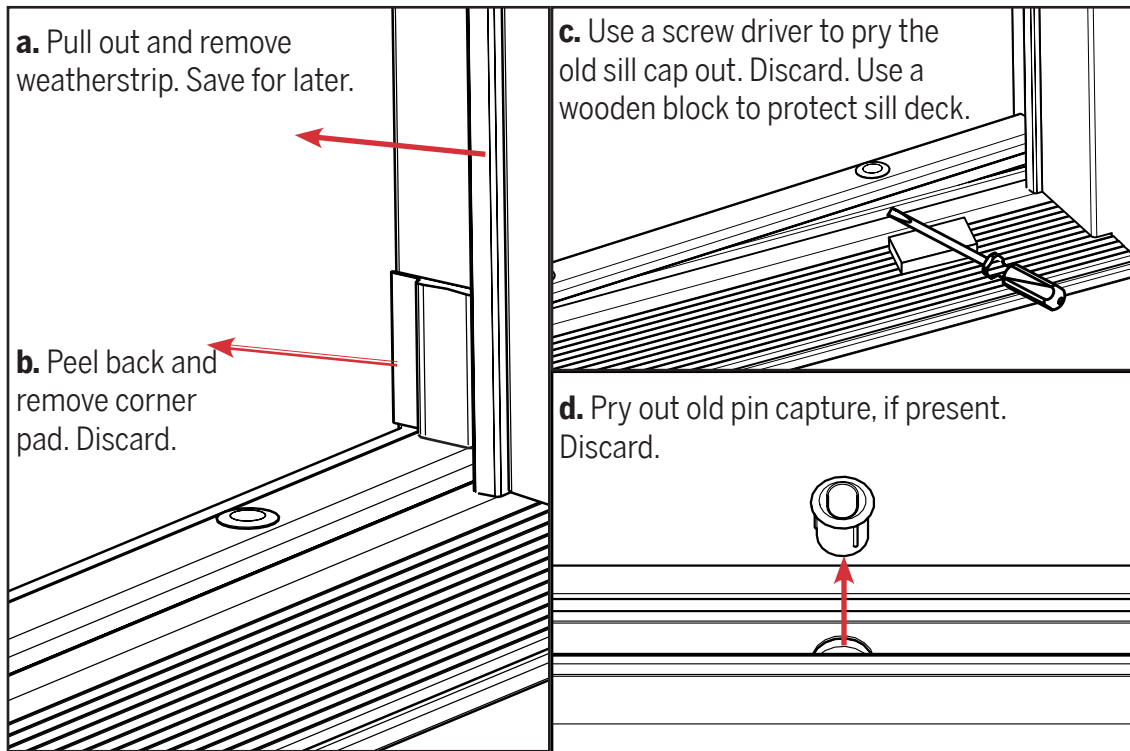

Step 2: Remove the door panels from the frame.

Remove the door panels by unscrewing at the hinges. Carry to a flat work surface and lay them horizontally.

We recommend you use assistance for this step.

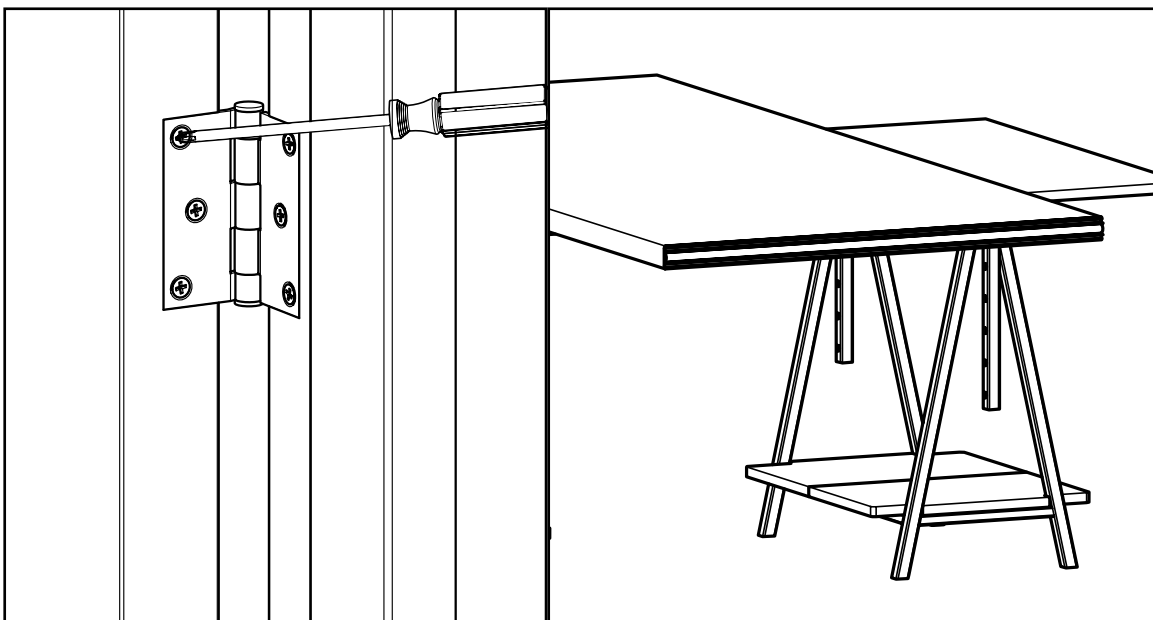

PART B: INSTALL COMPONENTS ON DOOR SILL

Step 3: Drill hole and install new pin capture.

If you already have a hole for the pin capture ensure that it is centered. If it is, you may start at step 4B. If not, you will need to drill a new hole.

A: Drill a new hole for the pin capture that is centered along the length and 7/16" from the sill dam.

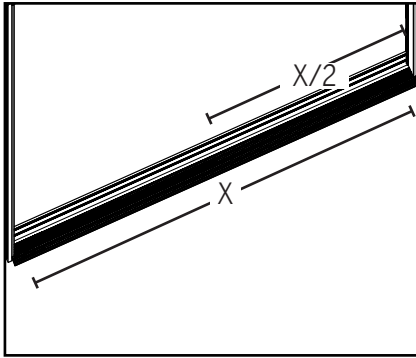

Measure the sill length and mark the mid point.

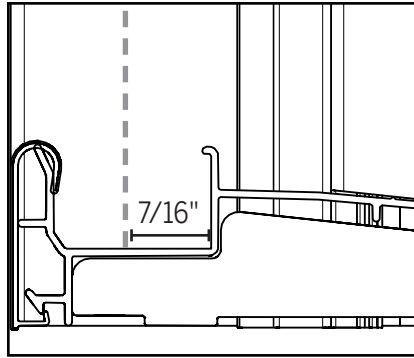

At this point, measure 7/16" from the sill dam.

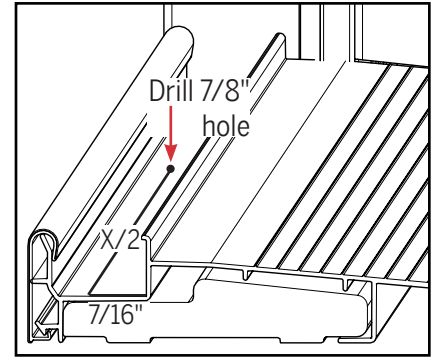

Drill hole for pin capture with a diameter of 7/8".

B: To install the new pin capture, apply exterior grade caulk and screw in the pin capture into the hole.

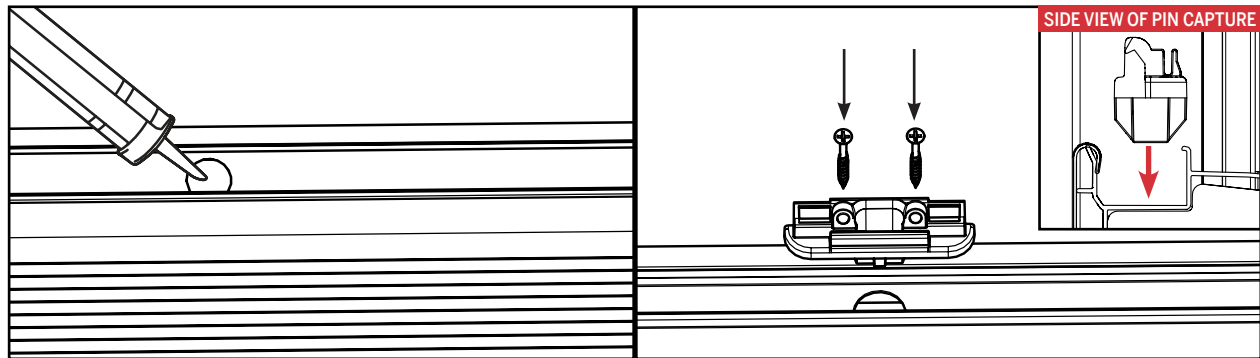

Step 4. Prepare and size your sill cap.

A: Remove the orange clips and discard. Also remove the two spring-loaded bases that are on each end of the sill cap. Keep these to return on cap after resizing.

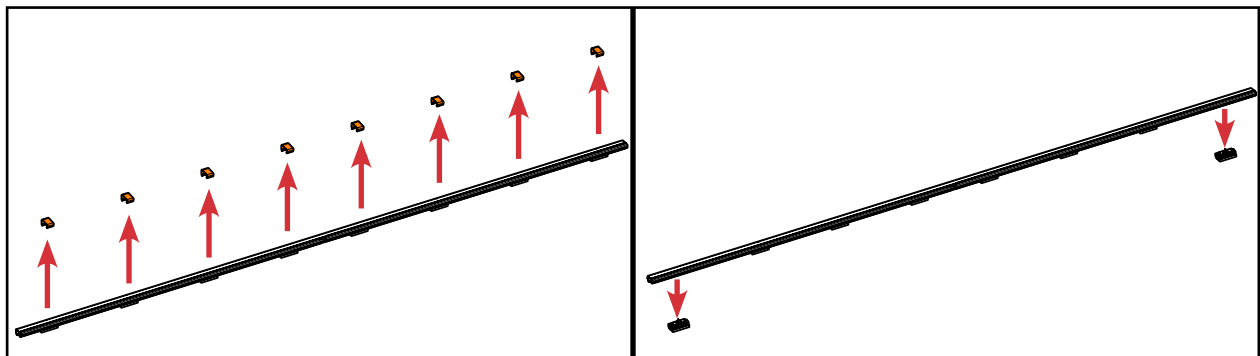

B: Measure the length of the sill (X). Now, measuring from the center of the pin capture notch, mark on one side of the sill cap at $X/2 - 1/8"$. Repeat the same on the other side. Cut with a saw along these marks.

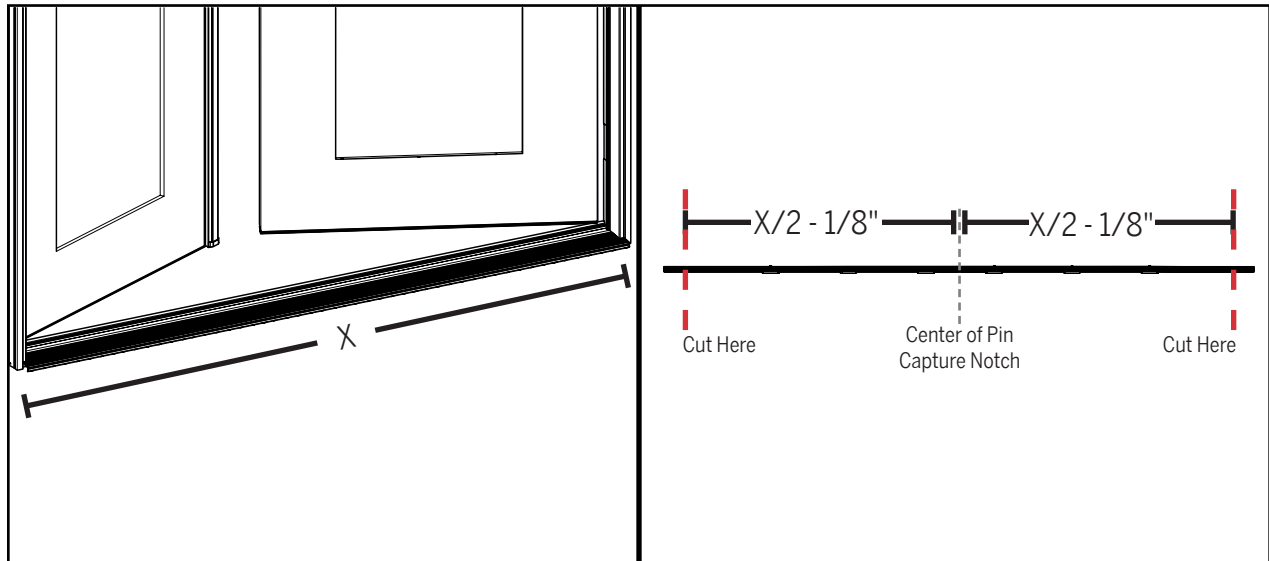

4C: Return the two spring loaded bases on each end of the cut sill cap.

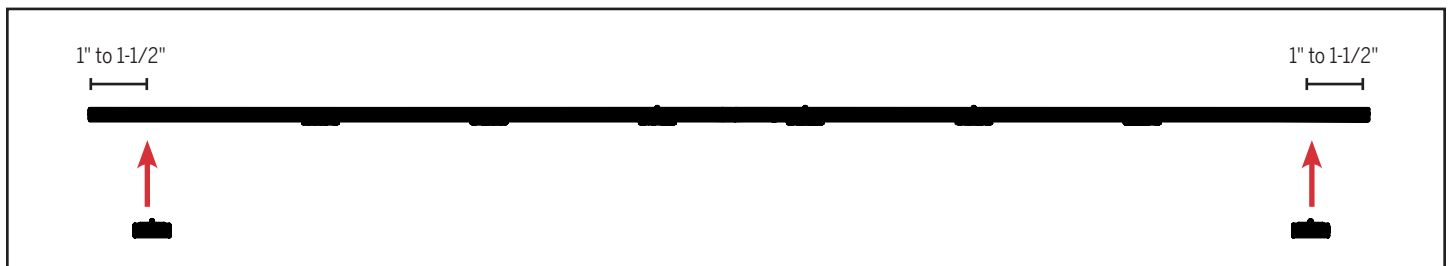

Step 5: Insert Mull Stiffeners.

Insert the mull stiffeners into the sill channel and slide to the end so it is flush with the jamb. The stiffeners are handed and will only go in one way. Repeat on the other side of the sill.

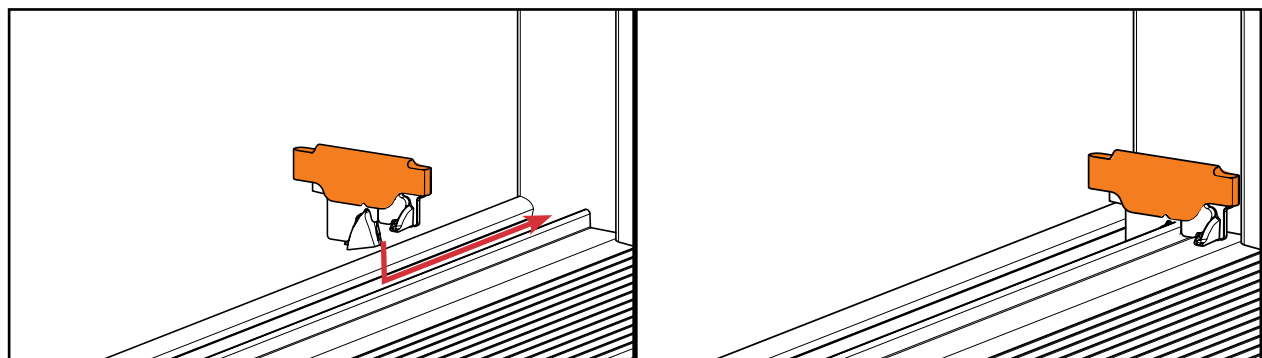

Note: Do not remove the orange protective label. Only remove after Step 7, when new sill cap is installed.

If you are replacing an existing ZAC 2.0 cap, you already have the Z-End Base installed and only need to replace the foam pad.

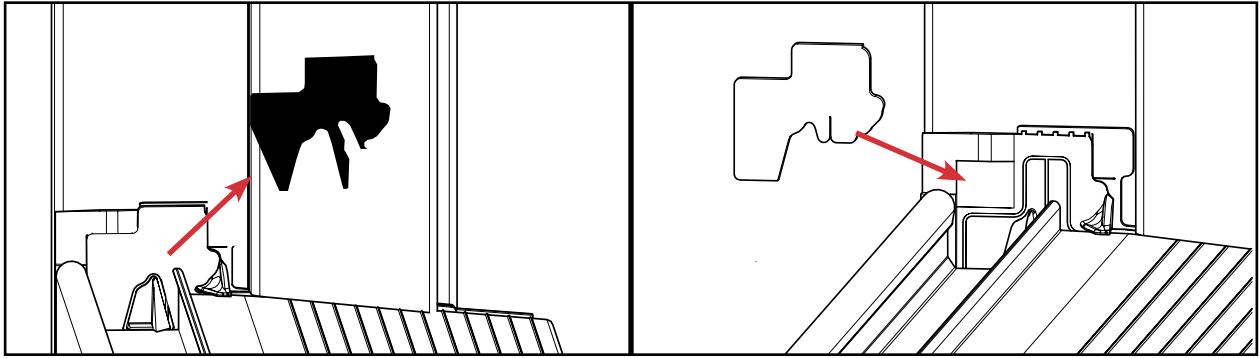

Step 6: Install new sill cap

To install new sill cap into the channel align the edges of the sill cap with the mull stiffeners and applying pressure evenly across the length to seat the cap in the channel.

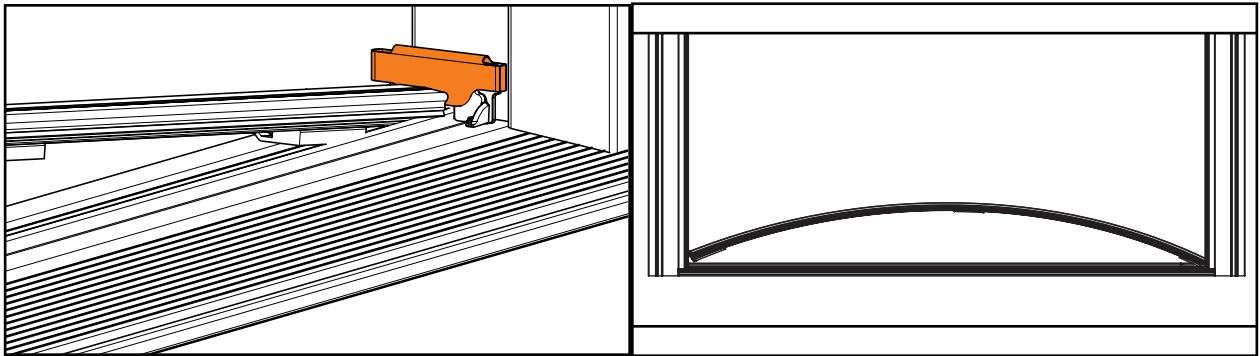

Align edge of cap with mull stiffener on one end.

Bend cap slightly to align the other edge with the mull stiffener on the other side.

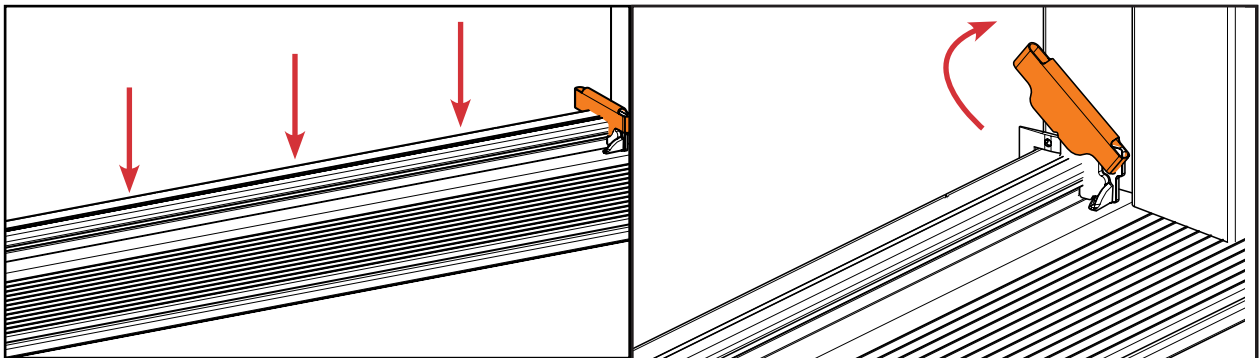

Apply pressure evenly across the cap length.

Remove the orange protective gasket.

Note: To confirm that the sill cap is well seated in the channel, ensure the front fin of the cap is touching the sill deck.

PART C: UPDATE DOOR PANEL COMPONENTS

Step 7: Remove the following components on the bottom of the door

Remove the door bottoms from both the active and inactive door panels. Use a flat head screw driver to pry off the door bottom from the bottom of the door panels. Identify type (Step 8) and discard.

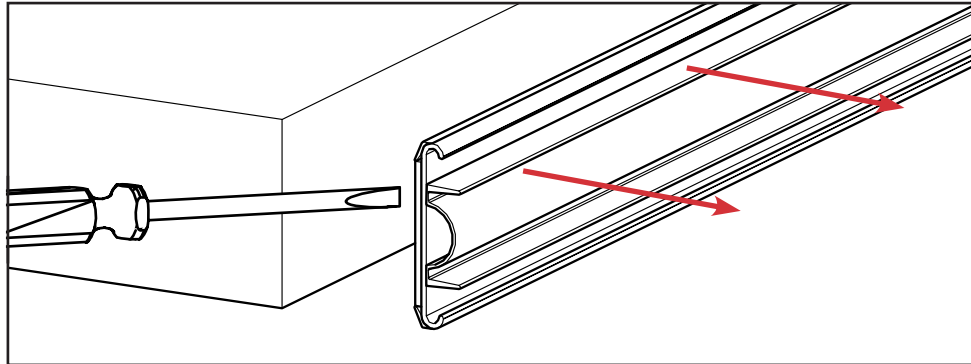

On the inactive door panel, remove these components from the astragal:

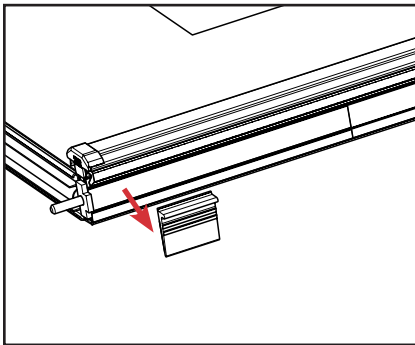

Peel off existing Corner Pad if present and discard.

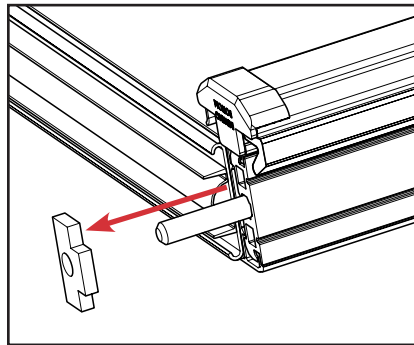

Remove astragal bottom gasket and discard.

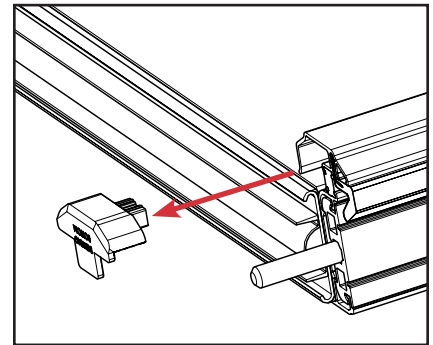

Remove old trim cap and discard.

Step 8: Identify your door bottom and cut the new door bottom to size.

A. Look at the door bottoms that you just removed, examining the side that was against the door panel.

- If it has kerfs or "legs" on it you have the Kerfed DB
- If it is flat you have the staple on DB.

You may discard the other and proceed with the appropriate steps for replacement.

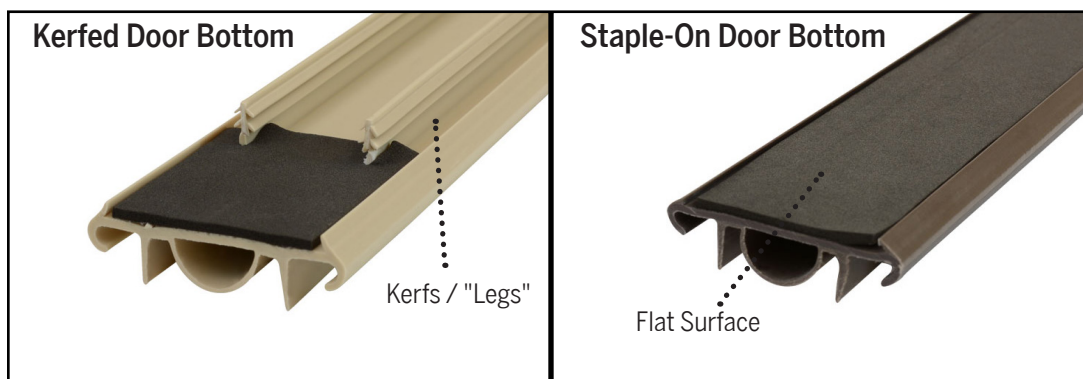

B. Measure the length of the door panels. Cut the door bottoms to match their lengths.

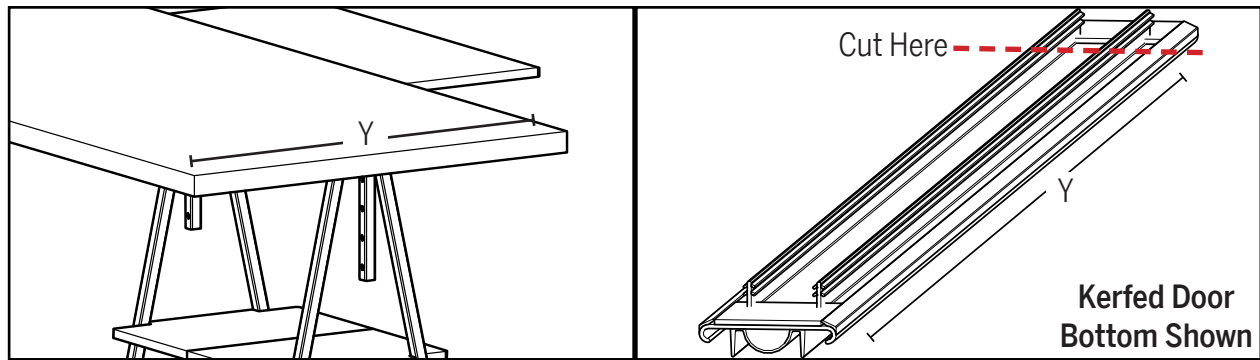

Step 9: Install the door bottoms

To install the door bottom on the panel, follow the appropriate steps for either Kerfed and Staple-On door bottoms.

Kerfed Door Bottoms

A: Measure the notch from the cut side of the door bottom. If the notch is less than 1-1/4", cut the kerf legs to create a notch that is 1-1/4". Be sure to do this for both door bottoms.

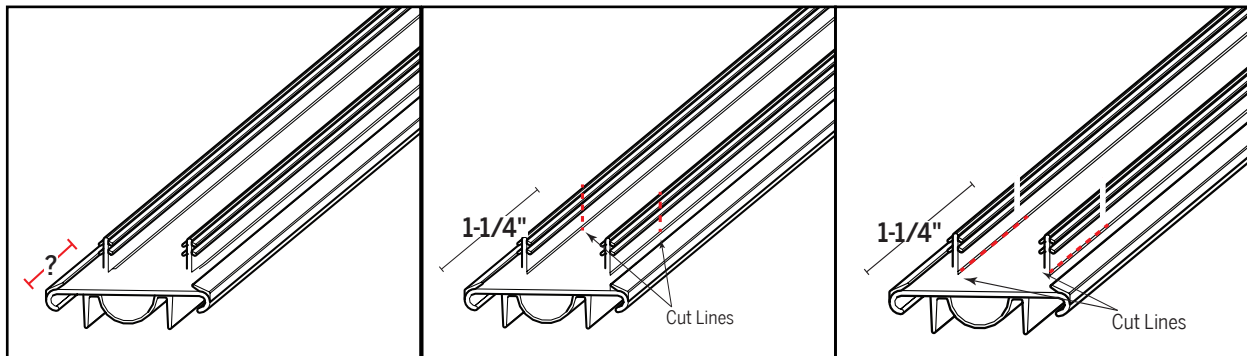

B: Apply the door bottom gasket, ensuring the solid edge is flush with the cut edge of the door bottom.

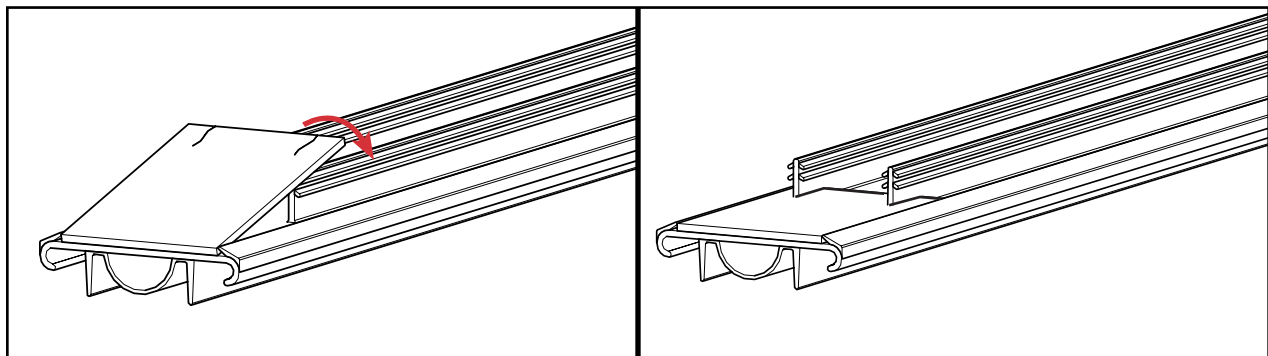

C: Install the new door bottom by inserting the kerf legs into the panel slots and secure each end with staples. Repeat for the other door panel.

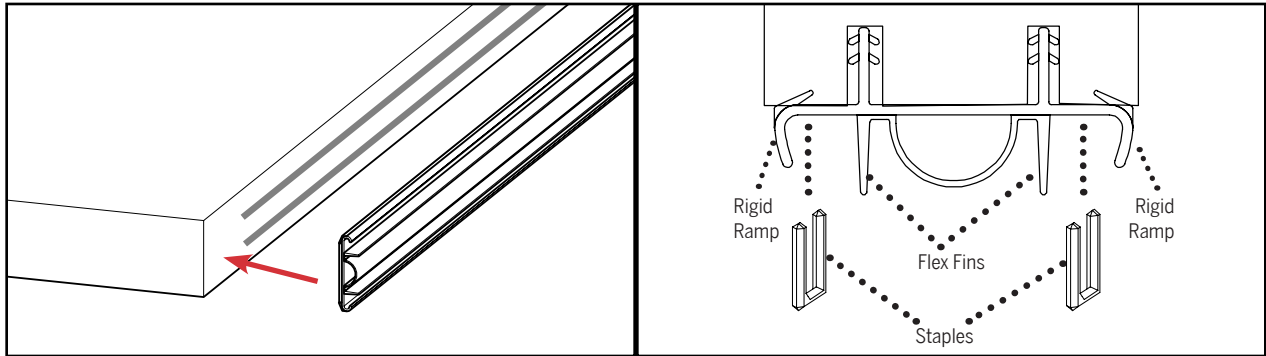

Staple-On Door Bottoms

A: Install new door bottom by aligning it with the panel and stapling along the length at 6" intervals.

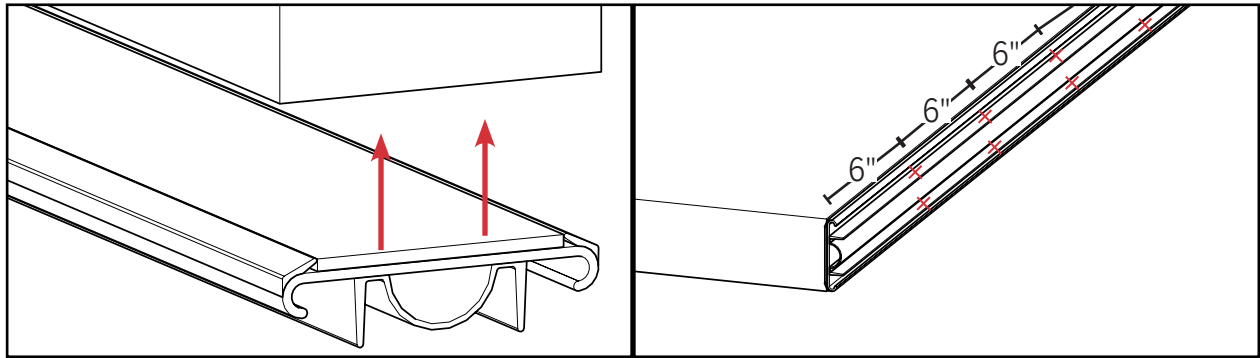

Step 11: Replace components around the astragal.

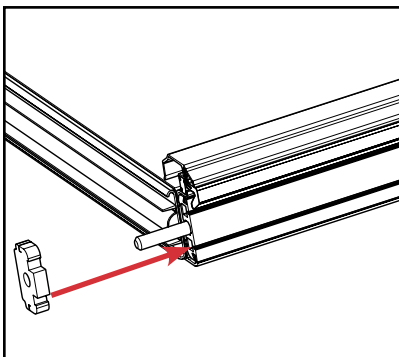

Engage flush bolt and align hole on the astragal bottom gasket with the bolt. Press against the panel.

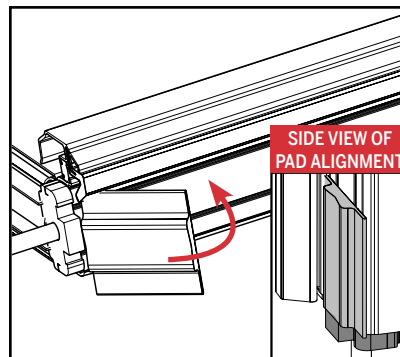

Tip the new corner pad into place. It will sit on the astragal bottom gasket.

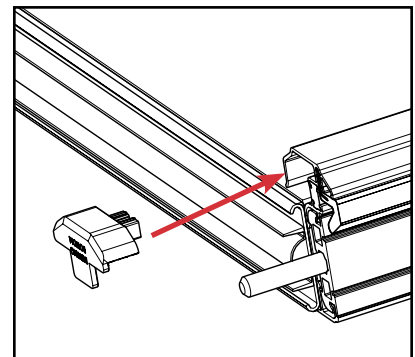

Align the trim cap with astragal body and insert into the bottom of the astragal.

Step 12: Return the door panels and weatherstrip.

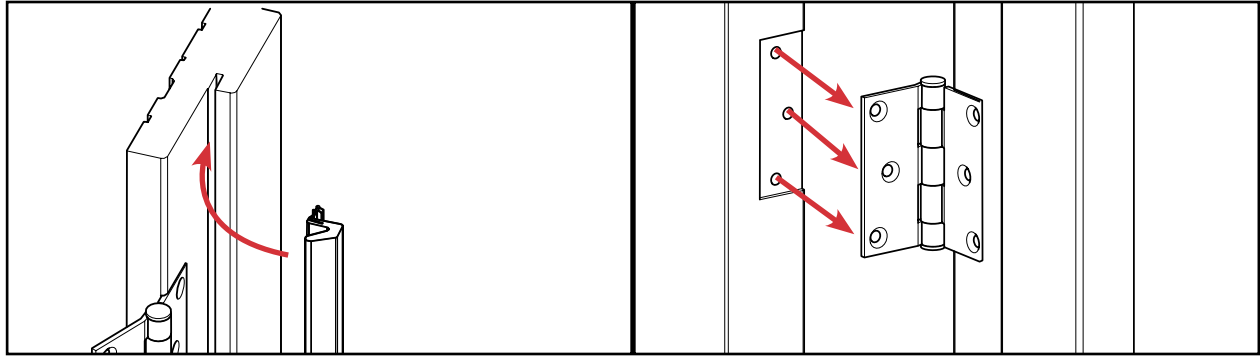

Return the weatherstrip pressing firmly along the jamb.

Realign the door panel and screw back into the hinges.

Step 13: Replace the corner pads on the jamb.

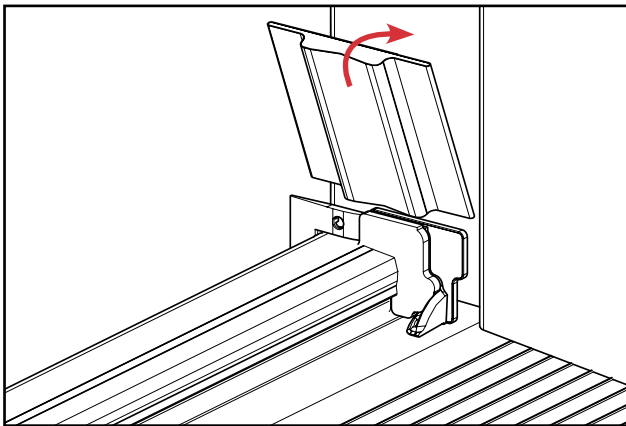

Remove paper backing and align bottom of corner pad flush against the top of the stiffener.

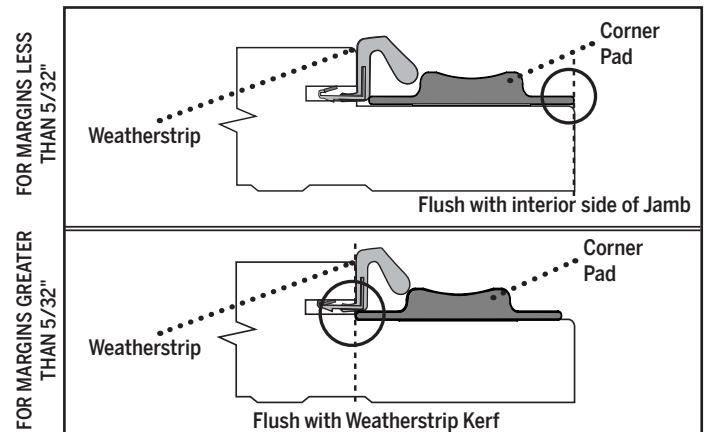

Align with weatherstrip and jamb based on strike margins. Press corner pad firmly against jamb and confirm the door operates properly. The sill cap should move up and down as the door opens and closes. Repeat on other side.

Confirm proper operation of the door. The sill cap should move up and down as you open and close the door.